

HERCULES

CONNECTOR

Ref. 0995

ROPE ACCESS, TEAM RESCUE, ROOFS

Forged aluminum alloy connector that is particularly easy to use with one hand.
 Compact, ergonomic design is ideal for use on cables, metal rings or temporary webbing anchors.
 Keylock closure prevents snagging during use.
 Double level locking system ensures a high level of safety and ease of use.

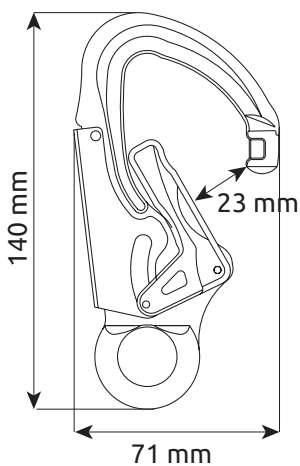

Ref.	Product name	Weight								CE			EAC
		g	oz							EN 12275	EN 362		
0995	HERCULES	125	4.4	30	9	16	23	140	71	K	T	•	•